



📞 1300 072 926

VIC 24-28 Williams Road Dandenong Sth. 3175  
E vic@globalmachinerysales.com.au  
F (03) 9791 7676

NSW Unit 1/21 Penny Place Arndell Park 2148  
E nsw@globalmachinerysales.com.au  
F (02) 8678 2478





**GOES THROUGH  
A STANDARD DOOR**



**TRANSPORTABLE  
WITH TRAILER  
EU DRIVING LICENCE B/E**

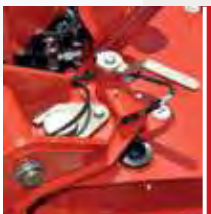

**THREE STABILIZATION  
AREAS**



**S.C.S.  
(SELF CONTROL SYSTEM)**



**RADIO CONTROL**



**FAULT DETECTOR  
DISPLAY**



**AUTOMATIC  
STABILIZATION**



A geometric platform, articulated with double pantograph, telescopic boom and Jib. The S23 contains the experience of the twenty-year success of the CMC. With its extremely compact dimensions (it can pass through a standard door) it is the ideal model for both interior and exterior work and, with its unparalleled strength, and its various stabilization possibilities, it is the ideal machine for every type of application.

## Standard equipment

The S23 is supplied with Honda Motor GX390 petrol engine, fixed undercarriage with black rubber tracks, fixed two-men basket 140x70x110 cm with quickrelease system and wheels, 200 bar air/water hose in basket, 230 V/110 V and 12 V electrical socket in basket, cylinder-outriggers cover, display for error code detection, proportional electro-hydraulic controls, S.C.S. by CMC (self stabilizing, automatic speed controls, "home function"), radio control, different stabilization: small, medium (right or left) large, parking-mode function (jib-lifting), 12 months warranty, standard painting (RAL 3000).

## Available accessories:

- +/-90° basket rotation
- Kubota Z602 diesel engine
- Variable undercarriage with adjustable tracks width
- Lithium battery (160 A)
- 230 V or 110 V electric motor
- Grey no-marking rubber tracks
- 1 or 2-men fiberglass basket
- Remote connection kit
- Fixed control station in the basket with display
- Customized colors

*The specifications and characteristics indicated are subject to change and are not binding.*







### TECHNICAL DATA

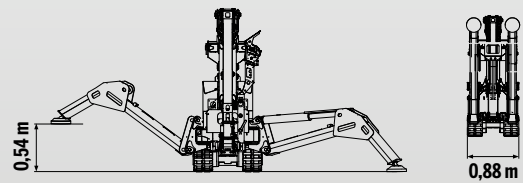
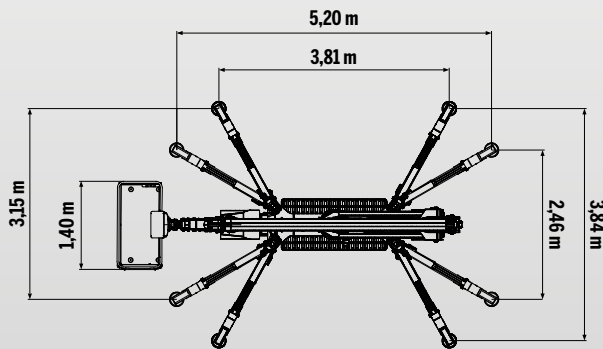
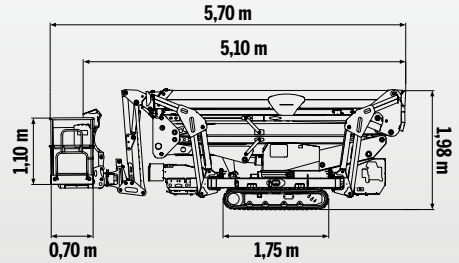
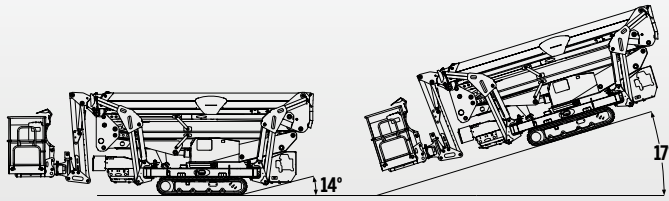

### MAXIMUM LOAD

200 KG +40 KG



### PERFORMANCE

- 23,00 m
- 12,40 m
- 200 Kg
- 1,4x0,7x1,1 m

- +/-90° optional
- +/-355° (710° continuous)
- 2984 Kg

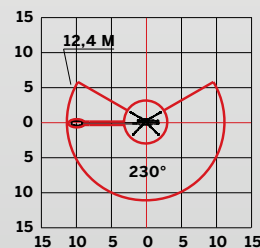
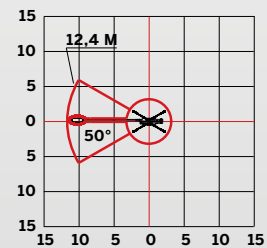
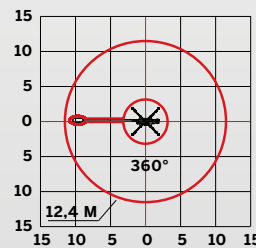
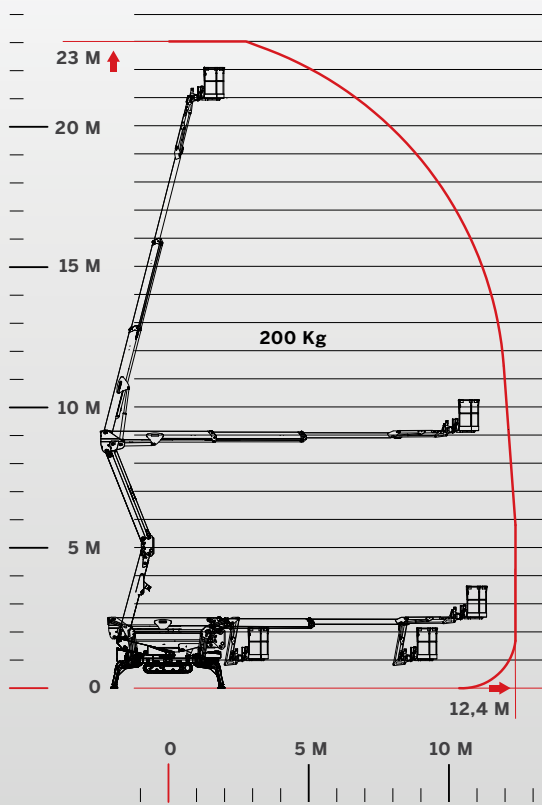



**A concentrate of technology.  
Strong, lightweight and easy  
to use: unstoppable.**

A geometric platform of the latest design, extremely light thanks to the use of high quality steels, a noteworthy feature that allows the S23 to be transported with a trailer, thus improving its possibilities of use. The simplicity of use combined with limited weight, transportability, plug & play technology and easy and intuitive use, make the S23 a platform that can not be missing in any fleet.

