



📞 1300 072 926

VIC 24-28 Williams Road Dandenong Sth. 3175
E vic@globalmachinerysales.com.au
F (03) 9791 7676

NSW Unit 1/21 Penny Place Arndell Park 2148
E nsw@globalmachinerysales.com.au
F (02) 8678 2478





**Small size,
“big” performance**

Compact, lightweight and multi-functional. S13F is the perfect solution for working in the most difficult conditions and in tight spaces, difficult to access. Full hydraulic with two working areas and two telescopic boom extensions, plus an articulating jib (90°). It's an easy to use, intuitive and fast platform. Thanks to its small size, it passes through a standard door and enters elevators.





**TOWABLE
WITH TRAILER**



**PROPORTIONAL
HYDRAULIC
CONTROLS**



**EMERGENCY
CONTROLS**



**WIRED REMOTE CONTROL
FOR TRACKS**



**GOES THROUGH
A STANDARD DOOR**



**HONDA ENGINE
GX390**



**QUICK
DETACHABLE
BASKET**



Compact, light and versatile, S13F is the perfect solution in the most difficult conditions and in the most narrow spaces. Fully hydraulic, with two working areas and a telescopic boom with 2 extensions plus jib (90 °) it is a platform simple to use, intuitive and fast. Thanks to its small size, it passes through a standard door and enters in the elevators.

Standard Equipment

S13F is supplied with Honda GX390 petrol engine, fixed undercarriage with black rubber tracks, fixed two-men basket 140x70x110 cm with rounded corners equipped with quick-release system and wheels, 200 bar air/water hose in basket, 12 V electrical socket in basket, 120 V auxiliary electric motor, outriggers cylinder cover, display for error code detection, proportional hydraulic controls, wired remote control for proportional travel mode, parking-mode function (jib-lifting), 12 months warranty, standard painting (RAL 3000).

Available Accessories:

- Yanmar Diesel engine L100N6CF1T1AA
- Honda iGX390 petrol engine
- Full lithium battery (160 Ah) version
- No marking tracks
- Hydraulic motors with double travel speed of tracks
- Basket rotation (90°+90°)
- 1 or 2-men fiberglass basket
- Remote connection kit
- Customized colors

The specifications and characteristics indicated are subject to change and are not binding.



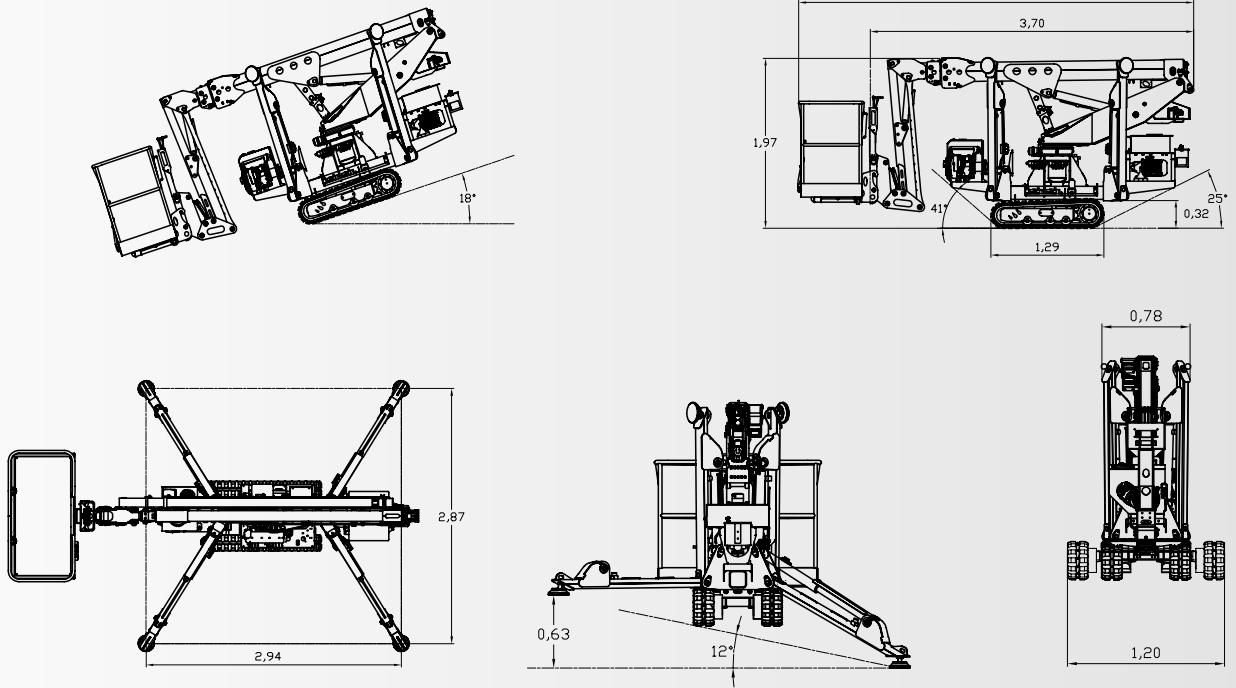

MAXIMUM LOAD

230 KG + + 40 KG 80 KG



PERFORMANCE



12,9 m



+/- 90°
optional



8,5 m



+/- 178° (356°
non continui)



230 Kg



1580 Kg



1,4x0,7x1,1 m

