



S15

VIC 24-28 Williams Road Dandenong Sth. 3175
E sales@globalmachinerysales.com.au

NSW Unit 49-50 Cassola Pl, Penrith NSW 2750
E sales@globalmachinerysales.com.au

QLD 191 Magnesium Dr, Crestmead QLD 4132
E sales@globalmachinerysales.com.au



globalmachinerysales.com.au



1300 072 926

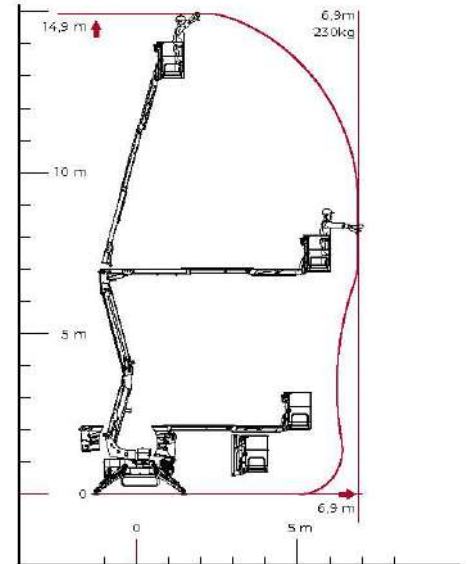

TECHNICAL SHEET

PERFORMANCE AND DIMENSIONS

Main features

This is the most compact geometric platform without outreach limiter in its class. It goes through a standard door and fit in the lifts, a key feature for use inside large structures such as airports or large shopping centres.

Max. working height 14,9 m

Max. reach with 230 kg 6,9 m

Platform height 12,9 m

Max. load in basket 230 kg

Basket dimensions 1,4 x 0,7 x 1,1 m

Basket rotation +/-90° (options)

Turret rotation +/- 178°(356° non-continuous)

Total weight 1820 Kg

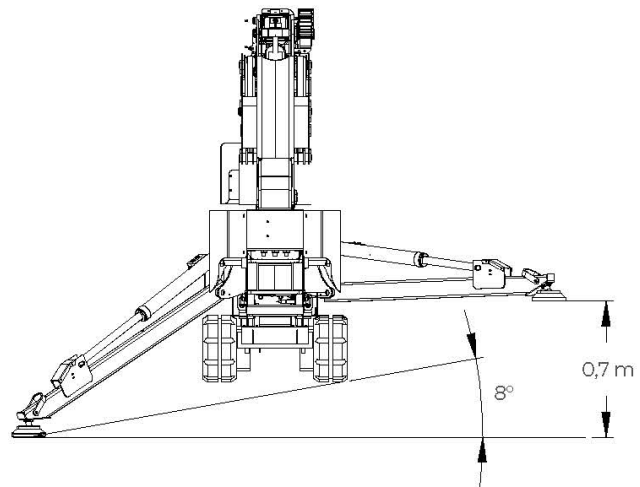
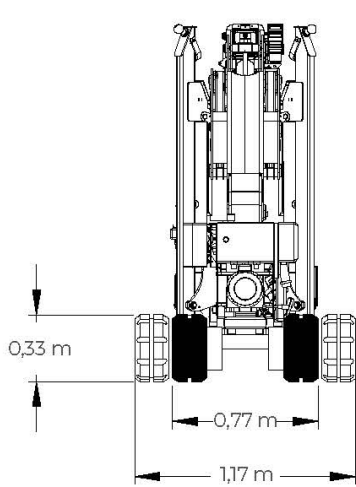
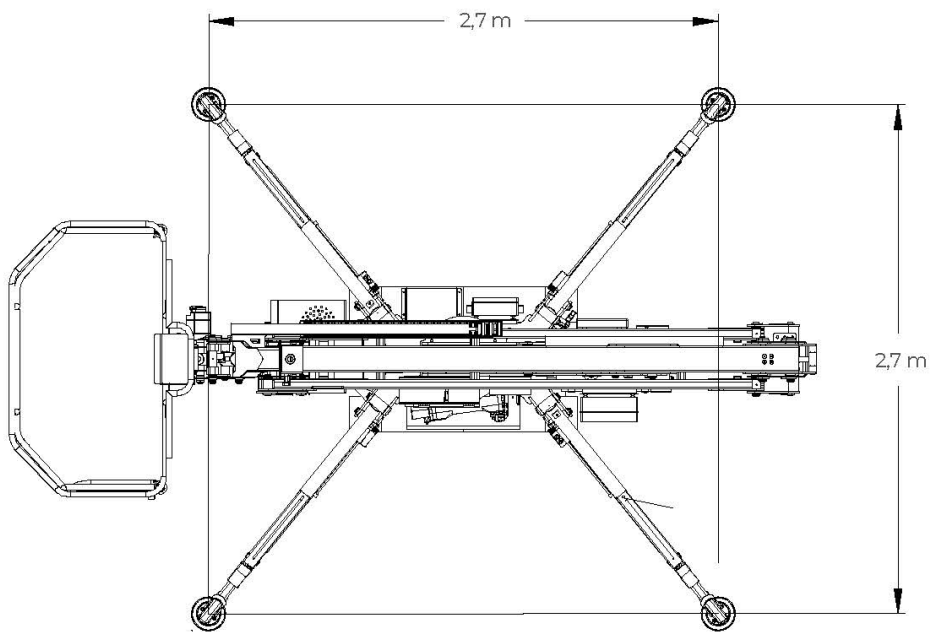
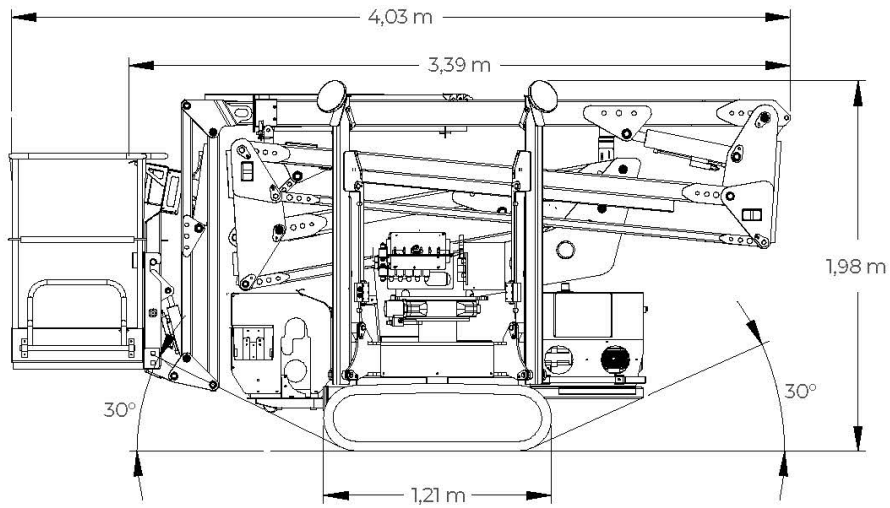

22-05-TS-EN-01