



S19E | LC Light and Compact Series

VIC 24-28 Williams Road Dandenong Sth. 3175
E sales@globalmachinerysales.com.au

NSW Unit 49-50 Cassola Pl, Penrith NSW 2750
E sales@globalmachinerysales.com.au

QLD 191 Magnesium Dr, Crestmead QLD 4132
E sales@globalmachinerysales.com.au



globalmachinerysales.com.au



1300 072 926

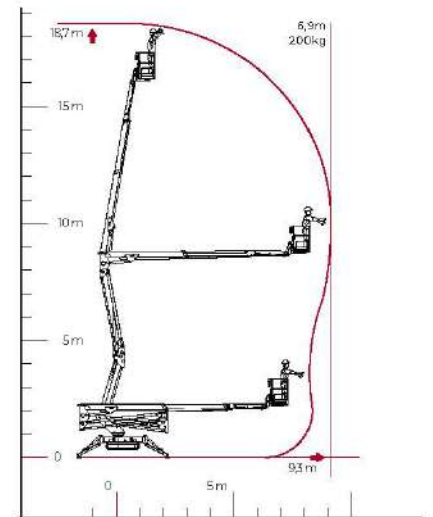

LC Light and Compact Series

TECHNICAL SHEET PERFORMANCE AND DIMENSIONS

Main features

A geometric platform, without outreach limiting device, with low weight and extreme compactness, easy to transport on a trailer and suitable for any type of application.

Max. working height 18,7 m

Max. reach with 200 kg 9,3 m

Platform height 16,7 m

Max. load in basket 200 Kg

Basket dimensions 1,4 x 0,7 x 1,1 m

Turret rotation +/- 178° (356° non-continuous)

Total weight 2545 Kg

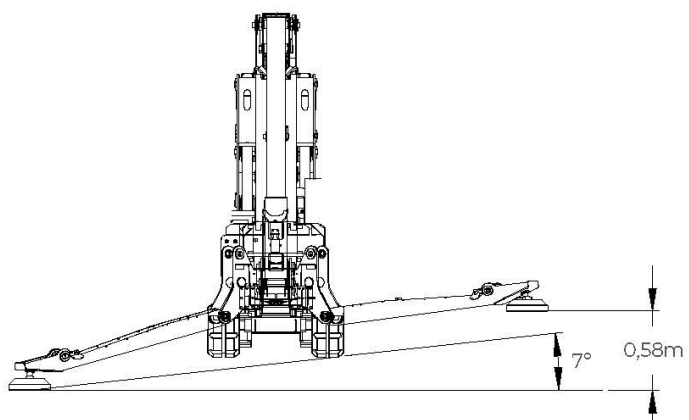
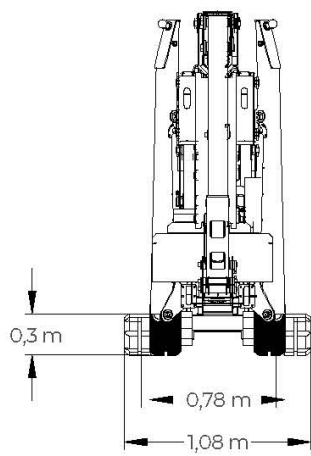
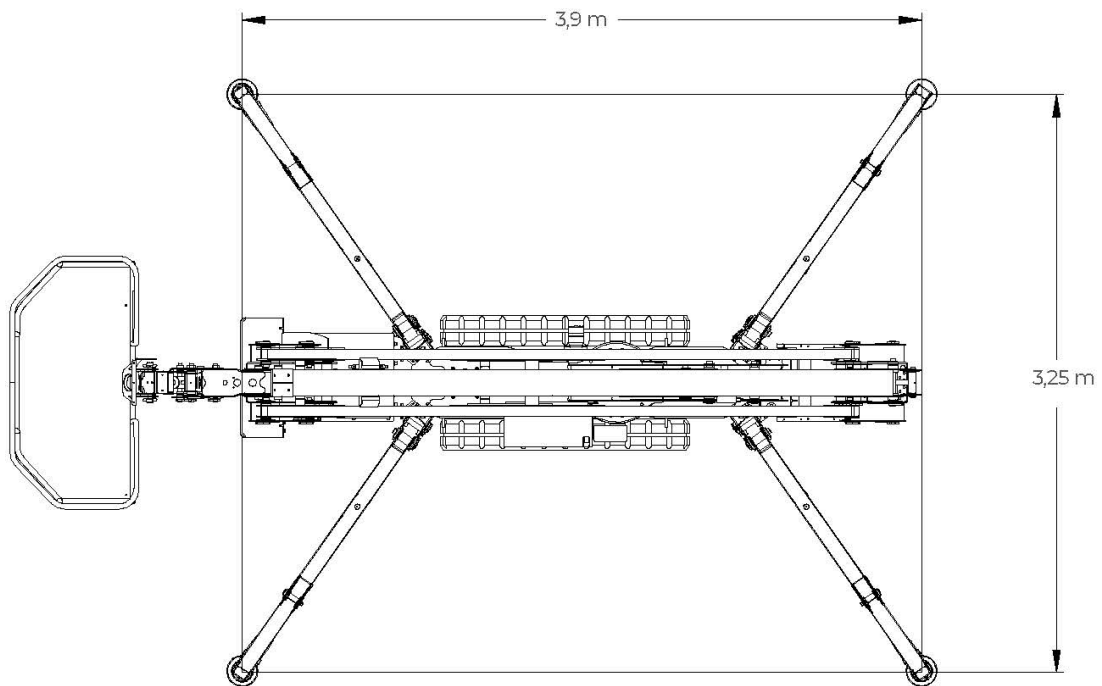
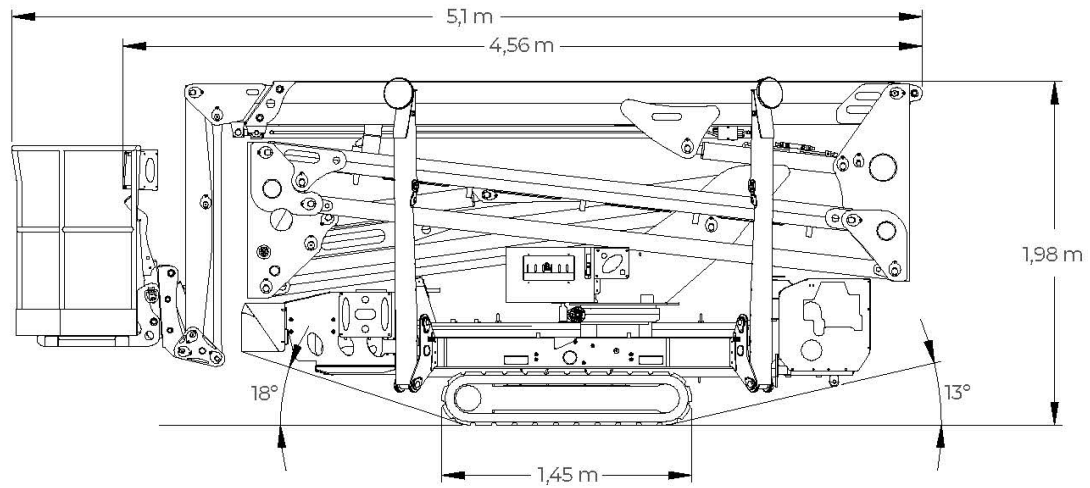

22-05-TS-EN-01