



S19N

LC Light and
Compact Series

VIC 24-28 Williams Road Dandenong Sth. 3175
E sales@globalmachinerysales.com.au

NSW Unit 49-50 Cassola PI, Penrith NSW 2750
E sales@globalmachinerysales.com.au

QLD 191 Magnesium Dr, Crestmead QLD 4132
E sales@globalmachinerysales.com.au



globalmachinerysales.com.au



1300 072 926

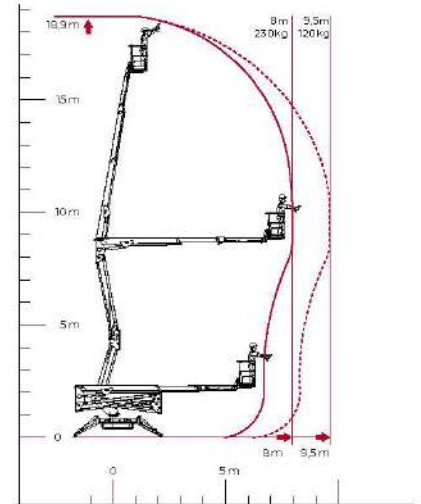

LC Light and Compact Series

TECHNICAL SHEET PERFORMANCE AND DIMENSIONS

Main features

N for Narrow, this platform featured the narrowest stabilisation area in its class.

It's the best tool to work in tight spaces without compromising the outreach performance.

Max. working height 18,9 m

Max. reach with 120 kg 9,5 m

Platform height 16,9 m

Max. load in basket 230 kg

Basket dimensions 1,4 x 0,7 x 1,1 m

Turret rotation +/- 178°(356° non-continuous)

Total weight 2435 Kg

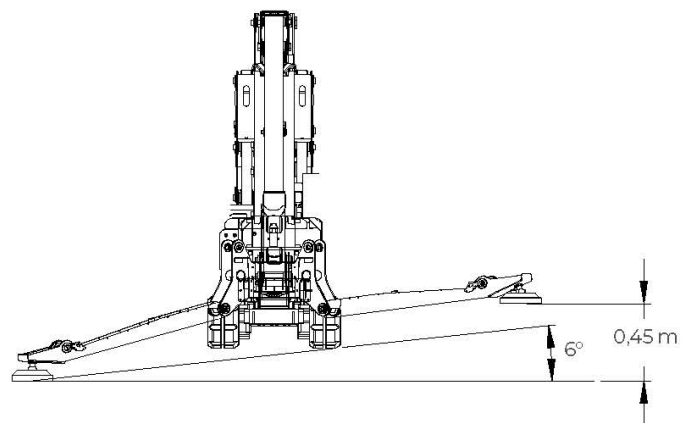
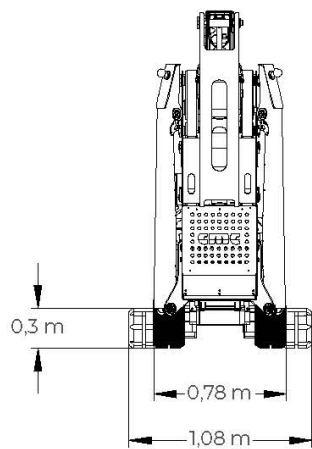
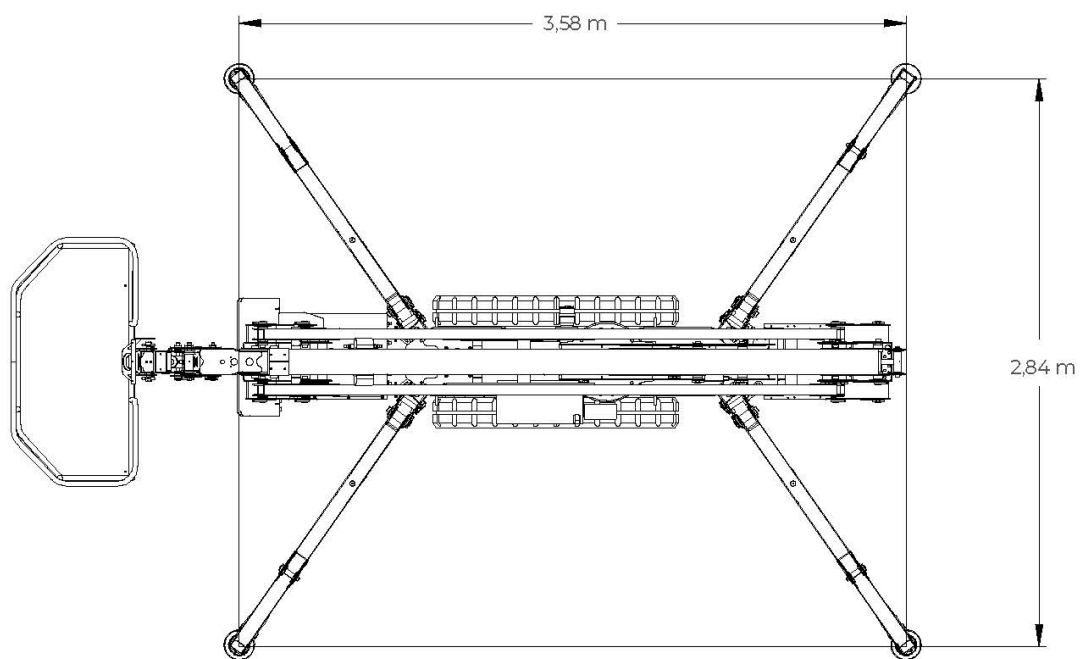
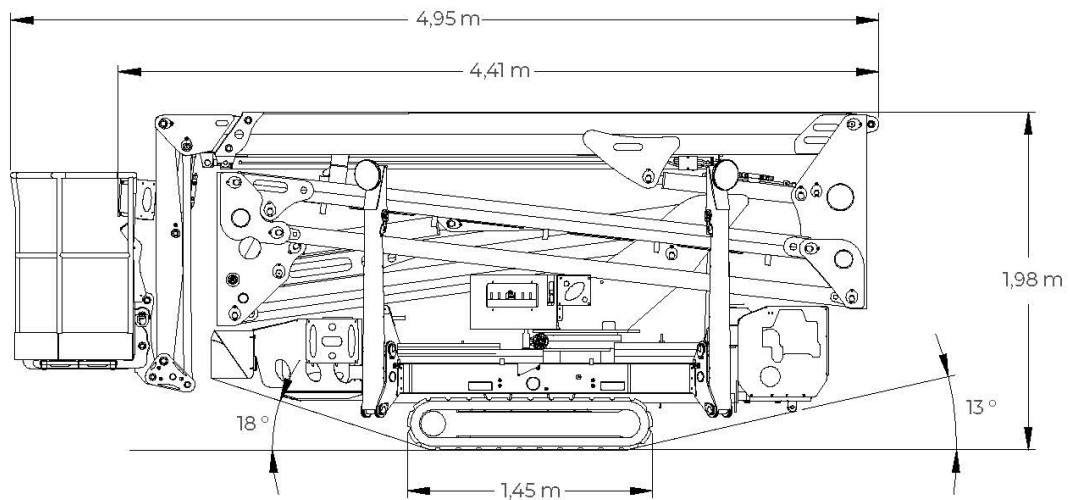

22-05-TS-EN-01